

**ATTENTION :** Il existe 2 configurations au niveau de l'arbre de transmission et des joints d'étanchéité associés. Choisir parmi les repères 11 à 13 ou 15 à 18, selon la hauteur des **plats d'entraînement** de l'arbre de transmission sur votre machine.  
 $h = 18,5 \text{ mm}$  ;  $H = 25,5 \text{ mm}$

**WARNING :** There are 2 configurations regarding the transmission shaft and the associated seals. Choose among indexes 11 to 13 or 15 to 18, according to the height of the transmission shaft **driving flats** on your machine.

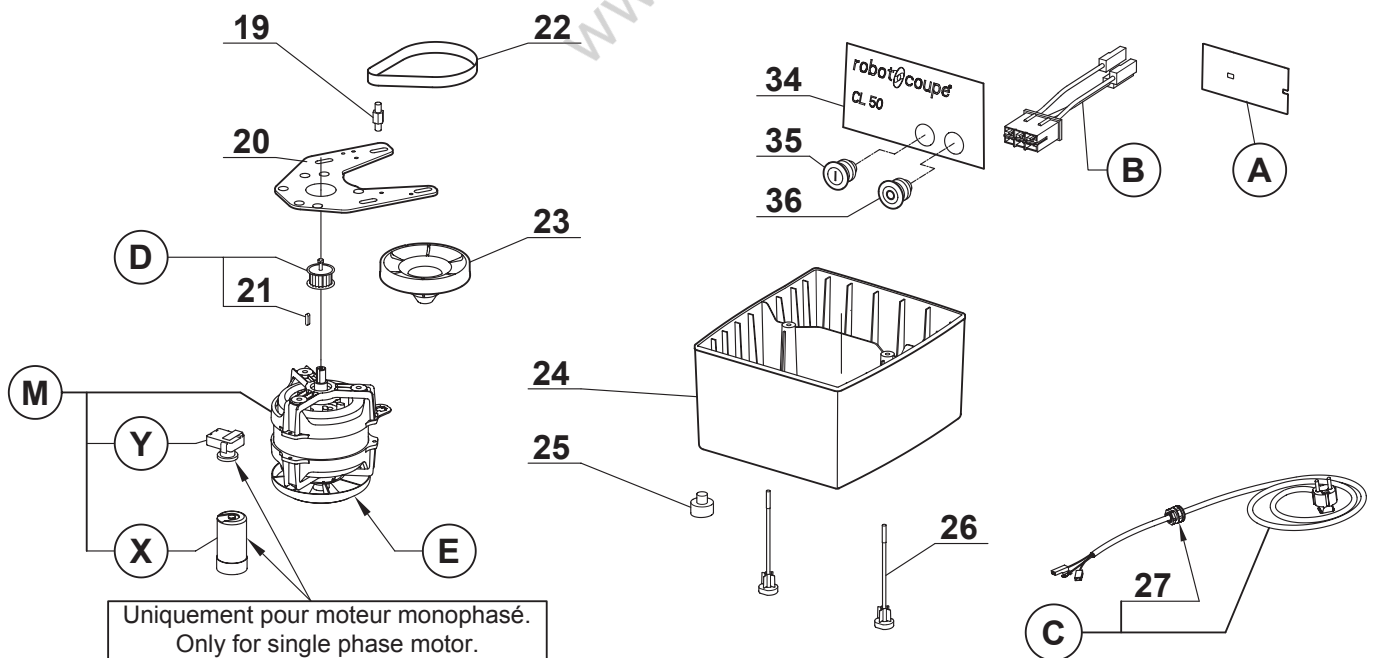
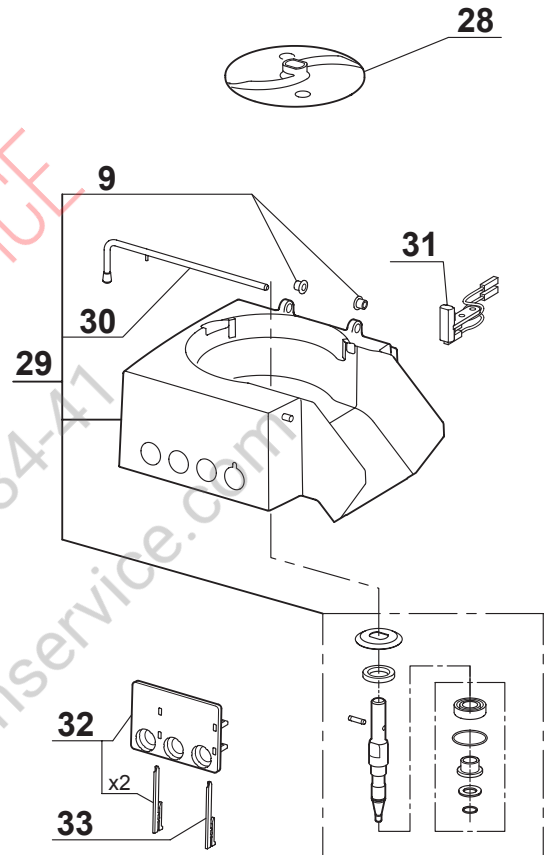
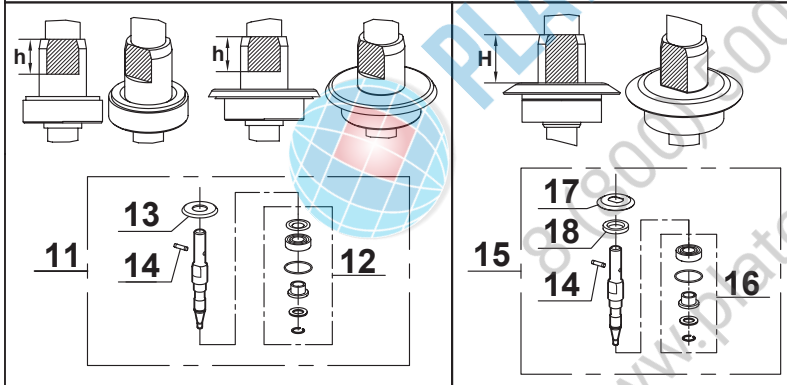

Uniquement pour moteur monophasé.  
 Only for single phase motor.

- A** CL50C 3 PHASE CIRCUIT BOARD
- B** MOTOR REED SWITCH
- C** POWER CORD AUST 6,35
- D** MOTOR PULLEY ASSY
- E** FAN
- M** MOTOR H50 230/50/1 CL50D
- X** CAPACITOR
- Y** RELAY MTRPH16-39

INDEX	REF.	DESIGNATION
1	29627	CL50D LID ASS
2	29060	R501U VEG. PUSHER ASS
3	102021	KNOB WASHER
4	29738	CL50D PUSHER GUIDE ASSY
5	39097	CONJ.GUIA EMPU.HORT.CL55
6	100638	CL50 PUSHER GUIDE RING
7	39098	CL50 GUIDE AXLE ASSEMBLY
8	118324	CL50D ROUND PUSHER
9	29058	CL50 SHOULDERED RING ASS.
10	29501	CLINCH CLIP D ASS
11	29629	CL50D DRIVING SHAFT ASSY
12	29630	CL50 D BEARING ASSY
13	39197	CL50D SEAL ASSY
14	110308	MOTOR SHAFT PIN
15	39198	CL50D RECEPT SHAFT ASSY
16	39273	ENSEMBLE ROULEMENTS + JOINTS (NOUVEAU)
17	101547	DEFLECTOR
18	501678	MOTOR SEAL 25x42x7
19	117692	SUPPORT PLATE BRACE
20	117689	MOTOR SUPPORT PLATE
21	502768	CLAVETTE 4X4X16
22	515482	BELT
23	117682	PULLEY 75 TEETH
24	117681	CAPOT CL50 BAS PLASTIQUE
25	117579	RUBBER FOOT CL50C
26	118387	COVER FIXING SCREW
27	515515	CORD PROTECTOR D16 SAREL9
28	102690	GREY SLING PLATE CL50D
29	39470	BOWL + SHAFT ASSY
30	100703	CL50 HINGE PIN
31	29451	CUTTER SAFETY SWITCH
32	29533	PCB SUPPORT ASSEMBLY
33	117703	PCB LOCKING KEY
34	406514	PLAQ FRONT CL50D
35	502170	FLAT GREEN KNOB I
36	502169	FLAT RED KNOB

**robot coupe**

**CL 50 D**

Pricelist in EUR

N°	M	Voltage	A	B	C	D	E	X	Y
24340	3114	220/240/50/1	102480	29599	507026	29530	118512	600018	500289
24341	3114	240/50/1	102480	29599	507029	29530	118512	600018	500289
24342	3114	240/50/1	102480	29599	507028	29530	118512	600018	500289
24343	3116	230/60/1	102480	29599	507026	29530	118512	603669	500289
24344	3115	120/60/1	102480	29599	507027	29530	118512	603669	500296
24345	303080	380/50/3	102479	29600	515570	29532	106025	---	---
24346	303077	220/60/3	102479	29600	515570	29532	106025	---	---
24347	303078	380/60/3	102479	29600	515570	29532	106025	---	---
24188	3114	220/240/50/1	102480	29599	503683	29530	118512	600018	500289
2703	3114	220/240/50/1	102480	29599	507026	29530	118512	600018	500289
2705	3114	220/240/50/1	102480	29599	507026	29530	118512	600018	500289
2796	3114	220/240/50/1	102480	29599	507026	29530	118512	600018	500289

**robot coupe**

**CL 50 D**

N°	M	Voltage	A	B	C	D	E	X	Y
2864	3114	220/240/50/1	102480	29599	507026	29530	118512	600018	500289
2704	303080	380/50/3	102479	29600	515570	29532	106025	---	---
2706	303080	380/50/3	102479	29600	515570	29532	106025	---	---
2863	303080	380/50/3	102479	29600	515570	29532	106025	---	---
2514	3114	240/50/1	102480	29599	507029	29530	118512	600018	500289
2517	303080	380/50/3	102479	29600	515570	29532	106025	---	---
24349	3114	220/240/50/1	102480	29599	504671	29530	118512	600018	500289

**CL50D - CL50D Ultra - CL50 Gourmet** 120V/60Hz - 220V/60Hz - 230V/50Hz 1~

SCHEMA ELECTRIQUE

ELECTRIC DIAGRAM

ELEKTRISCHES SCHALTBILD



**Important**  
Précautions  
Wichtiger Hinweis

Vérifier que le fil d'adaptation à la tension de votre réseau est correctement positionné .  
Check that the wire which allows the adaptation to the supply voltage is on the right terminal .  
Unbedingt prüfen, ob der Draht zur Anpassung an die Spannung Ihres Stromnetzes korrekt positioniert ist .

rouge / red / rot → 120V/60Hz  
violet / purple / violett → 220V/60Hz  
blanc / white / weiß → 230V/50Hz

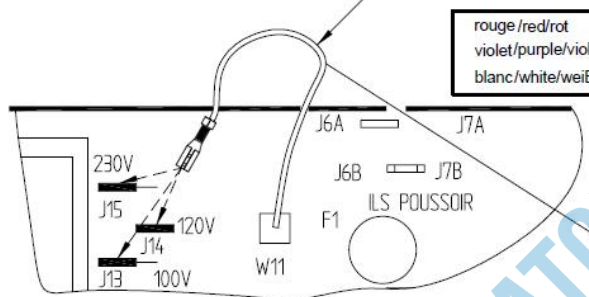

Français	English	Deutsch
C	Connecteur	Steckverbindung
CD	Condensateur de démarrage	Anlasskondensator
ILS1	Interrupteur sécurité couvercle	Kontakt Deckelverschluss
ILS2	Interrupteur sécurité poussoir	Sicherheitschalter Stosel
KD	Relais de démarrage	Anlassrelais
MO	Moteur monophasé	Motor einphasig
PCB	Carte de commande n° 102480	Komand Kart numer 102480
EA	Phase auxiliaire	Hilfsphase
EP	Phase principale	Hauptphase
SAR	Bouton poussoir arrêt	Stopschalter
SMA	Bouton poussoir marche	Betriebsschalter
θ	Protecteur thermique moteur	Motorthermoschutz

